



Activated Carbon Adsorbers

ACT series

Continuous operation, maximum compressed air quality

Flow rate 1.17 to 154.53 m³/min, Pressure 4 to 48 bar

<https://kaeser-kompressoren.by/vozduhopodgotovka-filtry-szhatogo-vozduha/>

ACT series

Continuous operation, maximum compressed air quality

Kaeser ACT series activated carbon adsorbers are true masters when it comes to delivering a continuous supply of premium quality compressed air that is technically oil-free and which is both odour- and taste-neutral. Installed downstream of compressed air drying and pre-filtration components, they attain Class 1 residual oil content as per ISO 8573-1 to ensure dependable protection of sensitive production processes.

They are therefore the perfect choice for applications in the optical, surface technology, electronics, foodstuffs and pharmaceutical sectors.

Technically oil-free compressed air

In order to meet the strictest Class 1 compressed air purity class requirements as stipulated by industrial standard ISO 8573-1, compressed air should have a residual oil content no higher than 0.01 mg/m³. Class 1 compressed air is therefore significantly cleaner than typical ambient air. For this reason, compressed air treatment is essential irrespective of the compression method that is used to produce it.

In order to achieve this level of purity, more is needed than to simply remove the residual fluid oil content via filters. The vapour component also needs to be retained by means of adsorption on activated carbon.

High performance ACT series activated carbon adsorbers from Kaeser can achieve residual oil content significantly lower than the threshold value for Class 1 compressed air purity.

Energy savings

Generously-dimensioned flow diameters, together with stainless steel flow diffusers, ensure even flow distribution with an exceptionally low pressure loss no higher than 0.1 bar. As a result, the compressor discharge pressure of upstream compressors, as well as the energy costs for compressed air production, can be kept as low as possible.

Exceptional reliability

ACT activated carbon adsorbers utilise a high quality and generously sized activated carbon filling. Optimised for gas purification, the special type of activated carbon is fine pored and possesses an exceptional retention capacity. Provided as original equipment, as well as for maintenance, the carbon used is abrasion-resistant, low-dust and has minimal ash content.

Furthermore, specially designed stainless steel flow diffusers ensure even flow distribution throughout the activated carbon bed. Consequently, the exceptional compressed air purity is reliably assured for up to 12,000 full load hours, or a maximum of five years.

Low life-cycle costs

When it comes to continuous compressed air demand, Kaeser ACT activated carbon adsorbers are hands-down winners from a cost perspective compared to typical activated carbon filters. Thanks to significantly longer service intervals, their life-cycle costs in the third year can equal those of high quality activated carbon filters. In the following years they are by far the more cost-effective alternative. This advantage is further bolstered by better compressed air availability resulting from the lower number of necessary service visits.

Basis:
Costs for investment, service (material, work and disposal), with the following replacement intervals: ACT activated carbon filling 12,000 operating hours, particulate filter 6,000 operating hours, activated carbon filter 1,000 operating hours; annual interest payments over 10 years.

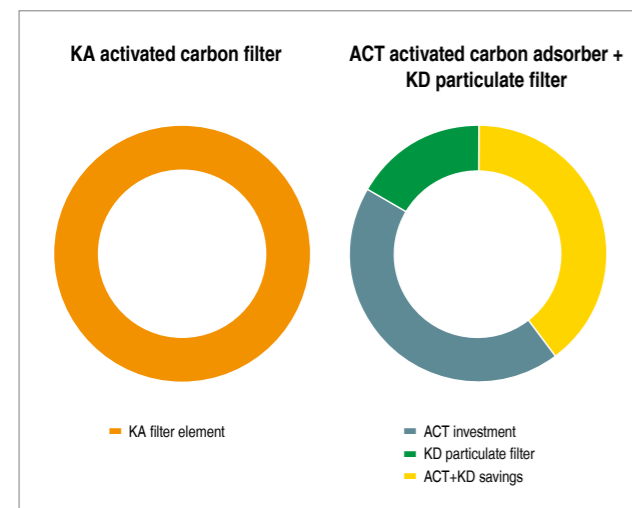

Image:
ACT 133 with accessory
KAESER FILTER (option)

Installation costs saved

Flexible position compressed air connections make on-site modification superfluous.



ACT series

Technically oil-free – with maximum cost-efficiency



Minimal pressure loss

ACT series activated carbon adsorbers feature generously sized cross-section pipework and tanks. They consequently operate with differential pressures (dp) no higher than 0.1 bar.



Long activated carbon service life

Generous fill volumes, high quality activated carbon and stainless steel flow diffusers allow the activated carbon filling in ACT series activated carbon adsorbers to deliver an exceptionally long service life of up to 12,000 full load hours, or a maximum of five years, without being changed.



Stable steel base frame

Kaeser ACT series activated carbon adsorbers are installed on a protective and exceptionally durable steel base frame.



Accessories: KAESER compressed air filters

ACT activated carbon adsorbers should always be equipped with KAESER filters. Installed as pre- and downstream filters, they ensure maximum service life of the activated carbon and, with minimal pressure loss, prevent carbon dust from being entrained in the cleaned compressed air.

Equipment

Standard equipment

Adsorption material tank including activated carbon filling, upper/lower stainless steel flow diffusers and separate upper/lower filling and emptying connections; equipped with tank pressure gauge and pressure regulator with oil indicator; pre-installed compressed air inlet and discharge line (flexible positioning); stable base frame, 2-component wet paint coating.

Options

- Silicone-free version as per VW test standard PV 3.10.7
- Working pressure 16 bar for models ACT 169 – 1545
- Working pressure 48 bar for models ACT 12 – 1545 HP

How it works

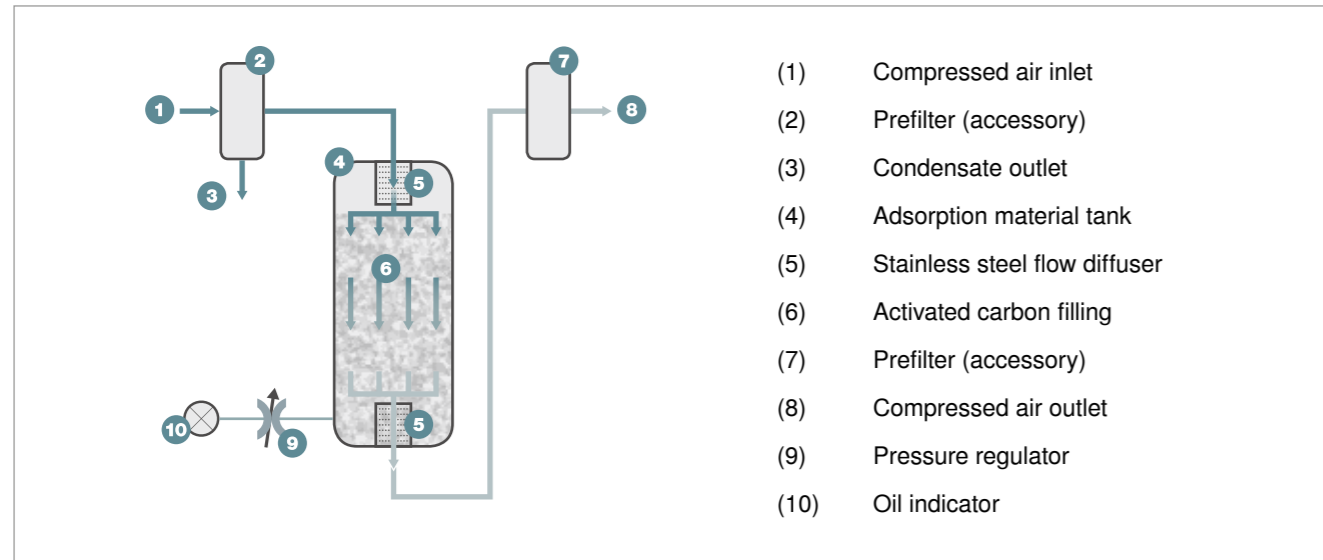

Technical specifications

Model	Flow rate * m³/min	Working pressure bar	Pressure loss bar	Compressed air connection	Ambient temperature °C	Max. temp. compressed air inlet °C	Dimensions W x D x H mm	Mass kg
ACT 12	1.17	4 ... 16	< 0.1	R ¾	2...45	2...55	350 x 750 x 1950	90
ACT 18	1.83	4 ... 16	< 0.1	R ¾	2...45	2...55	350 x 750 x 1950	110
ACT 27	2.67	4 ... 16	< 0.1	R ¾	2...45	2...55	350 x 750 x 1950	130
ACT 33	3.33	4 ... 16	< 0.1	R 1¼	2...45	2...55	350 x 750 x 1980	160
ACT 50	5.00	4 ... 16	< 0.1	R 1¼	2...45	2...55	550 x 750 x 1980	170
ACT 75	7.50	4 ... 16	< 0.1	R 1½	2...45	2...55	550 x 750 x 1990	215
ACT 108	10.83	4 ... 16	< 0.1	R 2	2...45	2...55	550 x 750 x 1990	260
ACT 133	13.33	4 ... 16	< 0.1	R 2	2...45	2...55	550 x 750 x 2000	330
ACT 169	16.88	4 ... 10	< 0.1	DN 80	2...45	2...55	800 x 1160 x 2215	275
ACT 215	21.47	4 ... 10	< 0.1	DN 80	2...45	2...55	800 x 1160 x 2505	310
ACT 266	26.62	4 ... 10	< 0.1	DN 80	2...45	2...55	960 x 1230 x 2385	360
ACT 323	32.33	4 ... 10	< 0.1	DN 80	2...45	2...55	1010 x 1230 x 2385	420
ACT 386	38.63	4 ... 10	< 0.1	DN 100	2...45	2...55	1010 x 1250 x 2595	430
ACT 444	44.35	4 ... 10	< 0.1	DN 100	2...45	2...55	1110 x 1454 x 2835	575
ACT 601	60.01	4 ... 10	< 0.1	DN 150	2...45	2...55	1110 x 1728 x 2868	625
ACT 859	85.85	4 ... 10	< 0.1	DN 150	2...45	2...55	1540 x 1965 x 2873	925
ACT 1173	117.73	4 ... 10	< 0.1	DN 200	2...45	2...55	1540 x 2169 x 2984	1200
ACT 1545	154.53	4 ... 10	< 0.1	DN 200	2...45	2...55	1580 x 2187 x 3297	1510

* Performance data at reference conditions: Working pressure 7 bar, ambient temperature + 25° C, compressed air inlet temperature + 35° C, PDP ≤ +3 °C; based on 1 bar ambient pressure absolute and 20 °C. The flow rate changes for deviating operating conditions.

Calculating flow rate

Correction factors for deviating operating conditions (flow rates in m³/min x k...)

Deviating working pressure p at filter inlet													
p bar _(g)	4	5	6	7	8	9	10	11	12	13	14	15	16
k _p	0.63	0.75	0.88	1.00	1.06	1.12	1.17	1.22	1.27	1.32	1.37	1.41	1.46

Compressed air inlet temperature T _i							
T _i (°C)	25	30	35	40	45	50	55
k _{Ti}	3.10	1.70	1.00	0.57	0.33	0.19	0.11

Example:				
Working pressure	8 bar	->	Factor	1.06
Compressed air inlet temperature	40 °C	->	Factor	0.57

ACT 133 activated carbon adsorber with 8.05 m³/min flow rate	
Max. possible flow rate under following operating conditions	
$V_{\text{max Operation}} = V_{\text{Reference}} \times k_p \times k_{Ti}$	
$V_{\text{max Operation}} = 13.33 \text{ m}^3/\text{min} \times 1.06 \times 0.57 = 8.05 \text{ m}^3/\text{min}$	

Dimensions

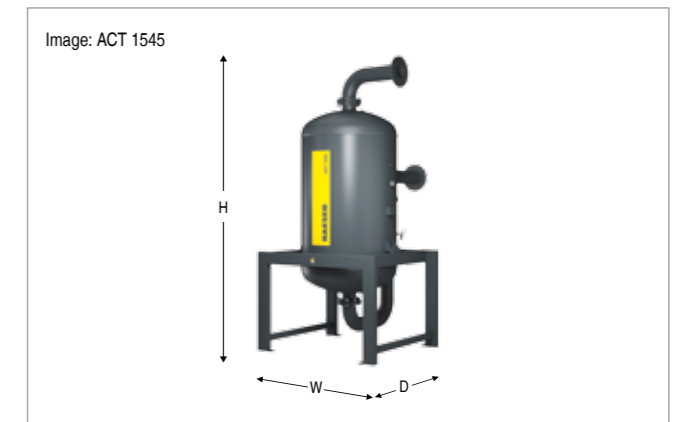
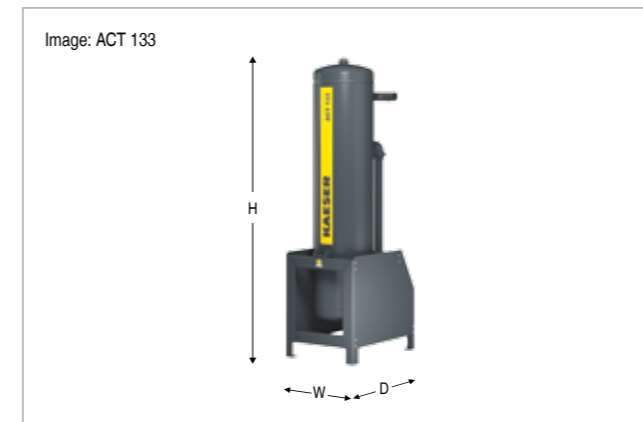

The world is our home

As one of the world's largest compressed air systems providers and compressor manufacturers, KAESER KOMPRESSOREN is represented throughout the world by a comprehensive network of branches, subsidiary companies and authorised partners.

With innovative products and services, KAESER KOMPRESSOREN's experienced consultants and engineers help customers to enhance their competitive edge by working in close partnership to develop progressive system concepts that continuously push the boundaries of performance and compressed air efficiency. Moreover, the decades of knowledge and expertise from this industry-leading system provider are made available to each and every customer via the KAESER group's global computer network.

These advantages, coupled with KAESER's worldwide service organisation, ensure that every product operates at the peak of its performance at all times and provides maximum availability.



ЗАО «САГБЕЛ»

220035, г. Минск, ул. Гвардейская, д. 8,
пом. 1, комн. 1.

E-mail: info@kaeser-kompressoren.by
+375 (17) 342-09-71, +375 (29) 348-86-12